

The best choice for bakeries producing a wide variety of products with a low volume production.

EZ Divider

Model code : CX011

Suitable for any type of dough!

Ideal for all types of dough: additive-free, natural yeast, long fermentation, high water absorption, rice flour, and more.

Accepts all types of dough-making methods!

Good for straight dough, sponge dough, overnight dough, brew dough, and all other methods.



RHEON

Divides dough quickly and accurately like a professional.



The dough is cut at the desired weight.

Place the dough on the conveyor from a tray. Then all you have to do is enter the cutting and weight and push the start button.

- Set the product weight and number of products and the machine will do the rest. Divides even as light as 20g of dough.
- The stress free system causes no damage to the dough and makes high quality products.
- Processes all types of dough: long fermentation, natural yeast, lean, high water absorption, and more.
- Solid ingredients such as raisins and nuts keep their shapes intact. Experience the smooth product changeover since the interior of the machine remains clean.
- Divides the dough without any residues.
- Just plug in the power, you're ready to go. Quiet operation due to the servo driven guillotine cutter.

Two distinctive production modes offer high efficient portioning.

Weighing cut mode

Weight accuracy in dividing the dough. Forms a batch of dough placed on the conveyor into a continuous strip of dough, weighs and divides the dough with high accuracy using the "Gravimetric method".

Forms into a continuous strip of dough.

Weighs and divides into consistent weight.

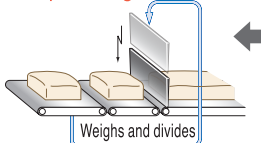

Provides corrected feed back. **Gravimetric method**



20 g: about 2,400 pcs/hour
350 g: about 450 pcs/hour

Dough Flow Direction

Baguette mode

Divides the dough on the conveyor evenly. Cuts the divided dough into equal sized pieces if needed. Useful for making products such as baguettes and rustiques that require consistent size.

Divides the width evenly.

Divides into preset number of dough pieces.



Traditional baguettes can be baked right after dough dividing!

Dough Flow Direction

Easy operation

Retrieve the product data from the memory and simply start production. Up to 100 production data can be memorized.



Easy cleaning and storage

Parts can be removed easily and safely. Conveyor folds compactly for a space-saving storage after production.



Capacity / Specifications

| | |
|----------------------------------|-------------------|
| Length | 2081 mm |
| Width | 1240 mm |
| Height | 1384 mm |
| Weight | 300 kg |
| Electrical Capacity | 0.59 kW |
| Production Capacity | * 40 shots / min. |
| Product Weight Range | 20 - 350 g |
| Maximum dough weight on conveyor | 7 - 8 kg |

※Actual weight range and maximum production capacity can vary depending on dough condition and supplied amount. Please test your products to find your actual numbers.

Dimensions

(Unit:mm)

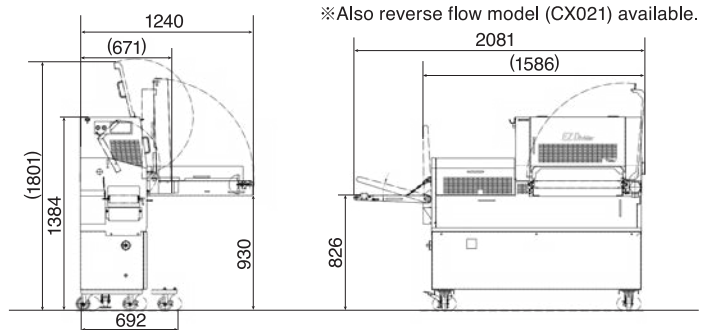

※Also reverse flow model (CX021) available.

The specifications are subject to change without notice and without obligation.

All Rights Reserved. Reproduction, adaptation or translation without prior written permission is prohibited.

RHEON

RHEON AUTOMATIC MACHINERY CO., LTD.

Head Office: 2-3 Nozawa-machi, Utsunomiya 320-0071, Japan
Phone: 028-665-1111 Fax: 028-666-1013 E-mail: info@rheon.com
URL: http://www.rheon.com

RHEON U.S.A.

2 Doppler, Irvine, CA 92618, U.S.A.
Phone: 949-768-1900 Fax: 949-855-1991 E-mail: us.info@rheon.com
URL: http://www.rheonusa.com

RHEON U.S.A. NJ BRANCH

375 North Street, Unit K, Teterboro, NJ 07608, U.S.A.
Phone: 201-487-0600 Fax: 201-487-0610 E-mail: us.east@rheon.com

RHEON AUTOMATIC MACHINERY GmbH

Tiefenbroicher Weg 30, 40472 Düsseldorf, F.R.Germany
Phone: 0211-471950 Fax: 0211-424129 E-mail: de.info@rheon.com
URL: http://www.rheon-europe.com

RHEON GmbH ULM BRANCH

Saumweg 30, 89257 Illertissen, F.R. Germany
Phone: 07303-1599410 Fax: 07303-15994111 E-mail: ulm@rheon.com

RHEON AUTOMATIC MACHINERY ASIA PACIFIC CO., LTD.

3F., No.180, Xinhua 2nd Rd., Neihu District, Taipei City 114 Taiwan (R.O.C.)

Phone: 02-8791-2227 Fax: 02-8791-1295 E-mail: tw.info@rheon.com

RHEON AUTOMATIC MACHINERY CO., LTD. SHANGHAI OFFICE

ROOM30, 5F GIFCII, 1438 Hongqiao Road, changning District, Shanghai

Phone: 86-21-61976378 Fax: 86-21-61976380